

16 + 2 Low Profile Hub

User Manual

Contents ---

One		
Introduction		2
Two		
Installation		3
Front Panel		
Connecting Ports		
LEDs		
Three		
Configuration and Installation Guidelines		5
Hub/Network Configuration		
Ports and Connectors		
Cable Schematic		
Four		
Troubleshooting and Technical Reference		8
Appendix		
Technical Support		10

1 Introduction

The Low Profile 100baseTX Fast Ethernet hub is an unmanaged 16+2 port stand-alone Class II repeater supporting a 100baseTX physical layer.

The hub can be used to connect centrally located fileservers or build workgroups, facilitating high density switch aggregation.

The Fast Ethernet hub works on the basis of a standard 100baseT repeater. A data packet received by any of the ports is repeated (transmitted) out of the other ports. Indicators (LEDs) provide Link and Disabled status.

The Installation and operation are simple. In case of difficulties consult the troubleshooting guide and technical specifications at the back of this manual.

Features

The Ringdale **Low Profile 100Base-TX** Hub provides the following features:

18 100baseTX ports half duplex for each port

Extensive front-panel diagnostic LEDs

Compact desktop and 19 inch rack mount version with **only 1U height**

100 Mbps throughput for high-performance data transfer

Internal all voltage power supply

Low latency, 45 bit times only

No software to load and configure

2 Installation

Connect the power cord to the socket on the rear panel of the hub and plug into power supply. Switch on the **Power** button located on the rear panel of the hub.

The **Power** LED lights up and the hub is ready for operation.

Front Panel

The figure below shows the front panel of the hub. Following are descriptions of the ports and LEDs.

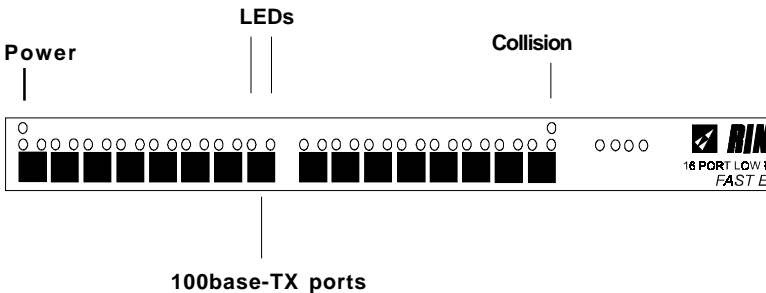

Connecting ports

Connecting Devices to the Hub

Simply insert the RJ45 cables from the required devices into the ports. Ensure that RJ45 cabling is wired up for Ethernet.

The ports support direct connection to any 100baseTX compatible adapter using Category 5 UTP cabling.

In addition, there are 2 extra ports located on the rear panel of the hub. These are **Uplink** ports and are used **only** to *daisychain* the hub to other hubs.

LEDs

The **Power** LED lights when the hub is switched on.

The **Collision** LED blinks when 2 or more packets are sent to the hub simultaneously. When this occurs the packets are rejected before being sent again.

Each port has 2 monitoring LEDs

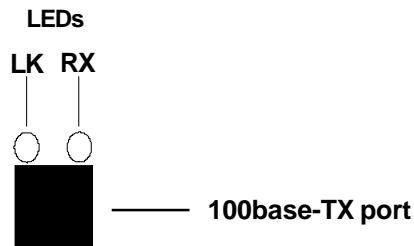

The **LK** (link) LED indicates that the port is functionally connected to an external port. It lights up when the connected adapters and the hub are turned on. If the LED does not light up, there may be a problem with the cabling or the adapter in the workstation or server.

The **RX** (received) LED shows activity on the port. The LED blinks on receipt of a data packet, regardless of the status of the port - even if the port is disabled.

Daisychain LEDs - These serve the same function as the LK/RX LEDs described above, only they refer to the 2 Uplink ports on the rear panel of the hub.

3 Configuration and Installation Guidelines

This section provides general guidelines on how to use the hub and how to fit it into your existing network.

The hub can be installed where existing bridges, hubs, routers and servers are located.

A typical location for the hub would be close to the data-centre, fileservers or computer room. It can also be installed in an office environment, however, it should be located within 100 metres of the attached server(s) and workstations.

Fast Ethernet ports and installations require UTP Category 5 cabling. UTP cables are sensitive to electrical noise, so ensure that your cabling is not near electrical noise such as fluorescent lights or power lines.

Ensure that the RJ45 cable is wired for Ethernet! Straight-through cables are used to connect adapters in servers or workstations.

The server or the workstations must have 100base TX compatible adapters (interfaces) installed.

Hub/Network Configuration

Attached servers and workstations can be connected to the hub by UTP cables of less than 100 metres and two hubs can be connected from node to node as long as the distance through the hubs is less than 210 metres.

This figure is arrived at because the maximum distance, including the equivalent distance of the hub between two nodes, on a Fast Ethernet network

is 400 metres. A Fast Ethernet hub is equivalent to 95 metres of cable, which gives under the *210 metre rule* the following calculation:

Cable Length	1st Hub	2nd Hub	Cable Remaining
400 M	- 95 M	- 95 M	= 210 M

Ports and Connectors

The hub ports use standard RJ45 connectors. The arrangement of the pins and the pinouts are shown in these figures together with the configuration of the twisted-pair cabling.

Position connector with gold contacts uppermost.

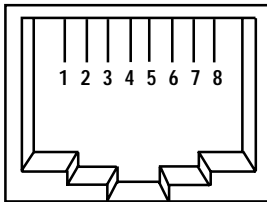

Port

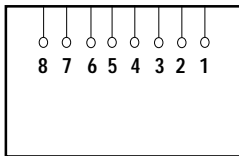

Cable
Connector

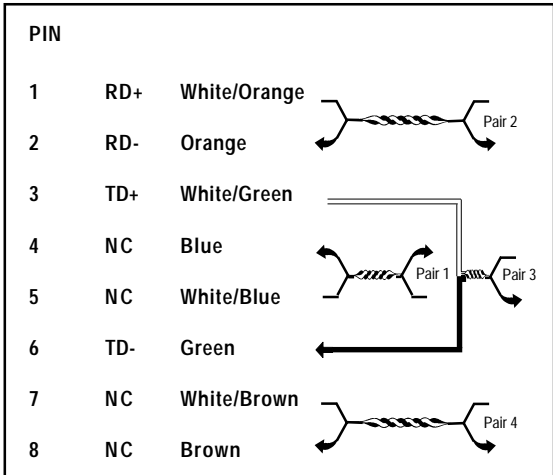

100Base-TX uses Pairs 2 and 3.

100Base-T4 and 100VG use pairs 1,2,3 and 4.

Fast Ethernet Cable Schematic

The shell for each connector is fixed to the chassis ground. The ports have their receive and transmit pairs internally crossed for attachment to an adapter using a straight-through cable. Schematics are shown below.

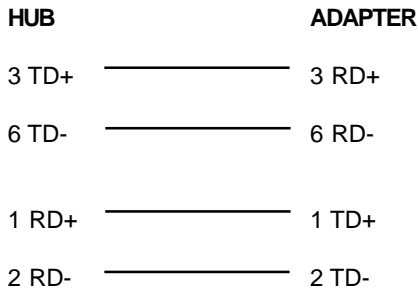

STRAIGHT-THROUGH SCHEMATIC

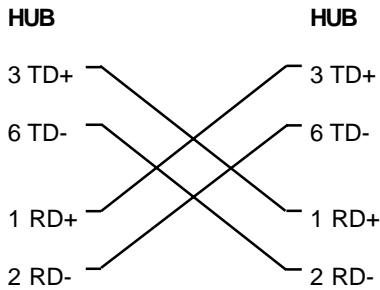

CROSSOVER CABLE SCHEMATIC

4 Troubleshooting and Technical Reference

Symptom	Poss. Cause	Action
Power LED does not light up	Power switched off	Switch on
	Power cord not connected	Plug in hub
	Fuse defect	Replace fuse
Link LED does not light up	No cable inserted	Connect to hub and Interface
	Interface (device) not powered up	Check power supply for devices
	Wrong cable type	Verify cable selection
	Bad cable	Replace cable
	Cable too long	Recalculate cable length

Technical Specifications

100base-TX 16+2 port low profile hub

Mains:	Input: 100...240V-AC Frequency: 50...60Hz Power: max.20 watts (18 port)
Ports:	18 half duplex 100baseTX ports
Interfaces:	100baseTX compliant standard via MIC interface RJ-45 ports for UTP CAT5 wiring and STP (shielded twisted pair)
Management:	SNMP and NPMP™ network management
Mounting:	18 port HUB: 19 inch EIA RS310-C or IEC pub 297 rack-mountable, with integral brackets
Technology:	Custom chipset - FastLink controller set
Speed:	100Mbps data rate for high performance data transfer Low port-to-port latency minimises delays through the hub
Part No:	18 port: 12-0302-0044

Appendix Technical Support ---

Ringdale Ltd, Ringdale Inc. and Ringdale GmbH all have Technical Support Departments. Their addresses and contact details are found on the back cover of this manual.

Before you call:

Please have the following information ready before calling:

Type of adapters installed in the System.
The adapter settings and interrupt options.

Network Information:
Network operating system type and version,
server configuration.

LAN topology:
Type of cable being used, size of network,
number of PCs and other nodes in network.

Computer Information:
Manufacturer, model number, operating
system used on the computer.

History of the Problem:
The symptoms of the problem.
Did the hub work for a period of time or fail
immediately after installation?
Was any PC option changed (hardware or
software) prior to the problem appearing?